



INSTALL CONFIDENCE



## YORK® SIDEWALL ACTIVE CHILLED BEAMS

### ENGINEERING GUIDE

# Contents

---

YORK® Sidewall Active Chilled Beams	3
CB-ABW-YK Performance Data	5
CB-ABW-YK Dimensions	10
Specifications	11

# YORK® Sidewall Active Chilled Beams

---

## Energy Efficiency Delivered

YORK® sidewall active chilled beams are the air distribution device of choice in high performing energy efficient buildings. Utilizing an integrated sensible cooling coil, active beams reduce the volume of air required for space cooling. A smaller volume of primary air minimizes energy consumed treating outdoor air and nearly eliminates energy wasted by parasitic reheat. When compared to conventional VAV systems a 30% energy savings is realized.

## Superior Performance

Aerodynamically designed nozzles inject conditioned primary air into the diffuser at high velocity. As the jets of air expand and slow the change in velocity creates a pressure gradient along its boundary. This pressure differential induces room air across the sensible coil within the diffuser. Using Computational Fluid Dynamics (CFD) and extensive laboratory testing the geometry of the YORK® under sill active chilled beams was refined to maximize induce air flow for optimal energy efficiency.

## Low Sound, Low Maintenance

Active chilled beams utilize system pressure in their operation, eliminating fans in the space or in the ceiling plenum minimizing overall system noise. With the elimination of fans, active chilled beams have no parts to replace for maintenance. Additionally, since coils are providing sensible cooling only there are no filters to be changed nor drain pans to clean; only periodic vacuuming of the coils to remove lint and dust from the coil and general cleaning of the exposed surfaces.

## High Style Design

In multi-story residential and hospitality spaces, the YORK® sidewall active chilled beams complement modern architectural styling and minimize installed space, as well as minimizing energy consumption. Superior comfort and near maintenance free operation of the CB-ABW-YK product family, combined with energy efficiency are an ideal solution in such demanding applications.

## Available Model:

CB-ABW-YK: Sidewall Active Chilled Beam



CB-ABW-YK

---

## Standard Features:

- 2 foot to 10 foot lengths, 1 foot increments
- 2-pipe and 4-pipe coil configurations
- Configured nozzle geometry for capacity optimization
- Commissioning port with roomside access for balancing
- 1/2" Sweat water coil connections
- Coil air vent
- Perforated grille

## Options and Accessories:

- Linear bar grille
- 1/2" thick foil-faced EcoShield, anti-microbial external insulation
- Coil drain valve
- 1/2" MNPT water coil connections
- 12-inch, 18-inch or 24-inch stainless steel braided hoses

CB-ABW-YK: PERFORMANCE DATA (4-PIPE COOLING)

Nominal Length ft	Nozzle Size	Primary Air			Sound NC	Coil Sensible Cooling (Btu/h)								Induction ratio	Throw ft.
		Inlet Dia.	Flow Rate	Inlet ΔPS		0.5 GPM		1.0 GPM		1.5 GPM		2.0 GPM			
		Inches	CFM	(in. H2O)		qCOIL	ΔCOIL	qCOIL	ΔCOIL	qCOIL	ΔCOIL	qCOIL	ΔCOIL		
3	B2	4	8	0.25	-	513	0.28	645	1.11	694	2.50	729	4.44	4.4	1 - 2 - 6
			12	0.50	23	678		853		917		964			2 - 4 - 9
			14	0.75	27	734		924		994		1,044			2 - 5 - 11
	B3	4	15	0.25	16	546	0.28	687	1.11	739	2.50	777	4.44	3.6	2 - 5 - 11
			22	0.50	27	762		959		1,031		1,084			5 - 8 - 13
			27	0.75	31	851		1,072		1,152		1,211			7 - 10 - 15
	B4	4	29	0.25	19	560	0.28	704	1.11	757	2.50	796	4.44	3.0	6 - 9 - 14
			40	0.50	31	857		1,079		1,160		1,220			10 - 13 - 18
			50	0.75	36	958		1,206		1,296		1,363			12 - 14 - 20
4	B2	4	11	0.25	-	550	0.36	692	1.43	744	3.22	782	5.72	4.4	1 - 2 - 6
			16	0.50	24	843		1,061		1,140		1,198			2 - 4 - 11
			19	0.75	28	941		1,185		1,274		1,339			3 - 6 - 13
	B3	4	21	0.25	17	638	0.36	803	1.43	863	3.22	907	5.72	3.6	2 - 5 - 12
			30	0.50	29	977		1,230		1,322		1,390			6 - 10 - 16
			37	0.75	33	1,092		1,374		1,477		1,553			8 - 12 - 17
	B4	4	39	0.25	-	788	0.36	991	1.43	1,066	3.22	1,120	5.72	3.0	8 - 12 - 17
			55	0.50	24	1,099		1,384		1,488		1,564			12 - 15 - 21
			67	0.75	28	1,228		1,546		1,662		1,747			13 - 16 - 23
5	B2	4	14	0.25	-	668	0.44	840	1.75	903	3.94	950	7.00	4.4	1 - 2 - 7
			20	0.50	26	1,023		1,288		1,384		1,455			2 - 5 - 12
			25	0.75	30	1,143		1,439		1,546		1,626			3 - 7 - 14
	B3	4	28	0.25	25	1,038	0.44	1,306	1.75	1,404	3.94	1,476	7.00	3.6	5 - 9 - 16
			40	0.50	29	1,149		1,447		1,555		1,635			7 - 11 - 17
			48	0.75	33	1,260		1,586		1,705		1,792			8 - 13 - 19
	B4	6" oval	46	0.25	-	871	0.44	1,096	1.75	1,179	3.94	1,239	7.00	3.0	8 - 12 - 18
			66	0.50	26	1,335		1,680		1,806		1,898			14 - 17 - 24
			80	0.75	31	1,491		1,877		2,018		2,121			15 - 19 - 27
6	B2	4	17	0.25	16	786	0.52	990	2.07	1,064	4.66	1,118	8.28	4.4	1 - 2 - 8
			25	0.50	28	1,205		1,517		1,631		1,714			2 - 5 - 14
			30	0.75	32	1,346		1,694		1,822		1,915			4 - 8 - 16
	B3	4	33	0.25	26	1,354	0.52	1,704	2.07	1,832	4.66	1,925	8.28	3.6	5 - 10 - 17
			47	0.50	31	1,266		1,594		1,714		1,801			8 - 12 - 19
			58	0.75	35	1,484		1,868		2,009		2,111			9 - 14 - 21
	B4	6" oval	60	0.25	23	1,375	0.52	1,731	2.07	1,861	4.66	1,956	8.28	3.0	13 - 17 - 24
			85	0.50	29	1,621		2,041		2,194		2,306			16 - 19 - 27
			104	0.75	34	1,843		2,319		2,494		2,621			17 - 21 - 30

CB-ABW-YK: PERFORMANCE DATA (4-PIPE HEATING)

Nominal Length ft	Nozzle Size	Primary Air			Sound NC	Coil Heating (Btu/h)								Induction ratio	Throw ft.
		Inlet Dia.	Flow Rate	Inlet ΔPS		0.5 GPM		1.0 GPM		1.5 GPM		2.0 GPM			
		Inches	CFM	(in. H2O)		qCOIL	ΔCOIL	qCOIL	ΔCOIL	qCOIL	ΔCOIL	qCOIL	ΔCOIL		
3	B2	4	8	0.25	-	1,359	0.09	1,710	0.37	1,839	0.82	1,933	1.46	4.4	1 - 2 - 6
			12	0.50	23	1,796		2,261		2,430		2,555			2 - 4 - 9
			14	0.75	27	1,946		2,449		2,633		2,768			2 - 5 - 11
	B3	4	15	0.25	16	1,447	0.09	1,821	0.37	1,958	0.82	2,058	1.46	3.6	2 - 5 - 11
			22	0.50	27	2,020		2,542		2,733		2,873			5 - 8 - 13
			27	0.75	31	2,256		2,840		3,053		3,209			7 - 10 - 15
	B4	4	29	0.25	19	1,483	0.09	1,867	0.37	2,007	0.82	2,109	1.46	3.0	6 - 9 - 14
			40	0.50	31	2,272		2,860		3,075		3,232			10 - 13 - 18
			50	0.75	36	2,539		3,196		3,436		3,611			12 - 14 - 20
4	B2	4	11	0.25	-	1,457	0.12	1,834	0.47	1,972	1.06	2,073	1.88	4.4	1 - 2 - 6
			16	0.50	24	2,233		2,811		3,022		3,176			2 - 4 - 11
			19	0.75	28	2,494		3,140		3,376		3,548			3 - 6 - 13
	B3	4	21	0.25	17	1,690	0.12	2,127	0.47	2,287	1.06	2,403	1.88	3.6	2 - 5 - 12
			30	0.50	29	2,589		3,259		3,504		3,683			6 - 10 - 16
			37	0.75	33	2,893		3,641		3,915		4,115			8 - 12 - 17
	B4	4	39	0.25	-	1,901	0.12	2,393	0.47	2,573	1.06	2,704	1.88	3.0	8 - 12 - 17
			55	0.50	24	2,913		3,667		3,943		4,144			12 - 15 - 21
			67	0.75	28	3,255		4,097		4,405		4,630			13 - 16 - 23
5	B2	4	14	0.25	-	1,769	0.14	2,227	0.58	2,394	1.29	2,516	2.30	4.4	1 - 2 - 7
			20	0.50	26	2,711		3,412		3,668		3,856			2 - 5 - 12
			25	0.75	30	3,028		3,812		4,098		4,308			3 - 7 - 14
	B3	4	28	0.25	25	2,750	0.14	3,461	0.58	3,721	1.29	3,911	2.30	3.6	5 - 9 - 16
			40	0.50	29	3,045		3,833		4,121		4,332			7 - 11 - 17
			48	0.75	33	3,339		4,203		4,519		4,750			8 - 13 - 19
	B4	6" oval	46	0.25	-	2,308	0.14	2,905	0.58	3,124	1.29	3,283	2.30	3.0	8 - 12 - 18
			66	0.50	26	3,537		4,452		4,786		5,031			14 - 17 - 24
			80	0.75	31	3,951		4,974		5,347		5,621			15 - 19 - 27
6	B2	4	17	0.25	16	2,084	0.17	2,623	0.69	2,820	1.54	2,964	2.74	4.4	1 - 2 - 8
			25	0.50	28	3,193		4,019		4,321		4,542			2 - 5 - 14
			30	0.75	32	3,567		4,490		4,827		5,074			4 - 8 - 16
	B3	4	33	0.25	26	3,587	0.17	4,515	0.69	4,854	1.54	5,102	2.74	3.6	5 - 10 - 17
			47	0.50	31	3,355		4,224		4,541		4,773			8 - 12 - 19
			58	0.75	35	3,933		4,951		5,323		5,595			9 - 14 - 21
	B4	6" oval	60	0.25	23	3,645	0.17	4,588	0.69	4,932	1.54	5,184	2.74	3.0	13 - 17 - 24
			85	0.50	29	4,296		5,408		5,814		6,111			16 - 19 - 27
			104	0.75	34	4,883		6,147		6,608		6,946			17 - 21 - 30

CB-ABW-YK: PERFORMANCE DATA (2-PIPE COOLING)

Nominal Length ft	Nozzle Size	Primary Air			Sound NC	Coil Sensible Cooling (Btu/h)								Induction ratio	Throw ft.
		Inlet Dia.	Flow Rate	Inlet ΔPS		0.5 GPM		1.0 GPM		1.5 GPM		2.0 GPM			
		Inches	CFM	(in. H2O)		qCOIL	ΔCOIL	qCOIL	ΔCOIL	qCOIL	ΔCOIL	qCOIL	ΔCOIL		
3	B2	4	8	0.25	-	574	0.38	723	1.50	777	3.38	817	6.00	4.4	1 - 2 - 6
			12	0.50	23	759		955		1,027		1,080			2 - 4 - 9
			14	0.75	27	822		1,035		1,113		1,170			2 - 5 - 11
	B3	4	15	0.25	16	611	0.38	770	1.50	827	3.38	870	6.00	3.6	2 - 5 - 11
			22	0.50	27	854		1,074		1,155		1,214			5 - 8 - 13
			27	0.75	31	954		1,200		1,290		1,356			7 - 10 - 15
	B4	4	29	0.25	19	627	0.38	789	1.50	848	3.38	892	6.00	3.0	6 - 9 - 14
			40	0.50	31	960		1,209		1,300		1,366			10 - 13 - 18
			50	0.75	36	1,073		1,351		1,452		1,526			12 - 14 - 20
4	B2	4	11	0.25	-	616	0.48	775	1.93	833	4.34	876	7.72	4.4	1 - 2 - 6
			16	0.50	24	944		1,188		1,277		1,342			2 - 4 - 11
			19	0.75	28	1,054		1,327		1,427		1,500			3 - 6 - 13
	B3	4	21	0.25	17	714	0.48	899	1.93	966	4.34	1,016	7.72	3.6	2 - 5 - 12
			30	0.50	29	1,094		1,377		1,481		1,557			6 - 10 - 16
			37	0.75	33	1,223		1,539		1,654		1,739			8 - 12 - 17
	B4	4	39	0.25	-	882	0.48	1,110	1.93	1,194	4.34	1,255	7.72	3.0	8 - 12 - 17
			55	0.50	24	1,231		1,550		1,666		1,751			12 - 15 - 21
			67	0.75	28	1,376		1,732		1,862		1,957			13 - 16 - 23
5	B2	4	14	0.25	-	748	0.59	941	2.36	1,012	5.31	1,063	1.20	4.4	1 - 2 - 7
			20	0.50	26	1,146		1,442		1,550		1,630			2 - 5 - 12
			25	0.75	30	1,280		1,611		1,732		1,821			3 - 7 - 14
	B3	4	28	0.25	25	1,162	0.59	1,463	2.36	1,573	5.31	1,653	1.20	3.6	5 - 9 - 16
			40	0.50	29	1,287		1,620		1,742		1,831			7 - 11 - 17
			48	0.75	33	1,411		1,777		1,910		2,007			8 - 13 - 19
	B4	6" oval	46	0.25	-	975	0.59	1,228	2.36	1,320	5.31	1,388	1.20	3.0	8 - 12 - 18
			66	0.50	26	1,495		1,882		2,023		2,126			14 - 17 - 24
			80	0.75	31	1,670		2,102		2,260		2,375			15 - 19 - 27
6	B2	4	17	0.25	16	881	0.70	1,109	2.78	1,192	6.26	1,253	1.44	4.4	1 - 2 - 8
			25	0.50	28	1,349		1,699		1,826		1,920			2 - 5 - 14
			30	0.75	32	1,508		1,898		2,040		2,144			4 - 8 - 16
	B3	4	33	0.25	26	1,516	0.70	1,908	2.78	2,052	6.26	2,156	1.44	3.6	5 - 10 - 17
			47	0.50	31	1,418		1,785		1,919		2,017			8 - 12 - 19
			58	0.75	35	1,662		2,093		2,250		2,365			9 - 14 - 21
	B4	6" oval	60	0.25	23	1,540	0.70	1,939	2.78	2,085	6.26	2,191	1.44	3.0	13 - 17 - 24
			85	0.50	29	1,816		2,286		2,457		2,583			16 - 19 - 27
			104	0.75	34	2,064		2,598		2,793		2,936			17 - 21 - 30

CB-ABW-YK: PERFORMANCE DATA (2-PIPE HEATING)

Nominal Length ft	Nozzle Size	Primary Air			Sound NC	Coil Heating (Btu/h)								Induction ratio	Throw ft.
		Inlet Dia.	Flow Rate	Inlet ΔPS		0.5 GPM		1.0 GPM		1.5 GPM		2.0 GPM			
		Inches	CFM	(in. H2O)		qCOIL	ΔCOIL	qCOIL	ΔCOIL	qCOIL	ΔCOIL	qCOIL	ΔCOIL		
3	B2	4	8	0.25	-	1,834		2,309		2,482		2,609		4.4	1 - 2 - 6
			12	0.50	23	2,424	0.38	3,052	1.50	3,281	3.38	3,449	6.00		2 - 4 - 9
			14	0.75	27	2,627		3,306		3,555		3,736			2 - 5 - 11
	B3	4	15	0.25	16	1,953		2,459		2,643		2,778		3.6	2 - 5 - 11
			22	0.50	27	2,726	0.38	3,432	1.50	3,690	3.38	3,878	6.00		5 - 8 - 13
			27	0.75	31	3,046		3,834		4,122		4,333			7 - 10 - 15
	B4	4	29	0.25	19	2,002		2,520		2,709		2,848		3.0	6 - 9 - 14
			40	0.50	31	3,068	0.38	3,862	1.50	4,152	3.38	4,364	6.00		10 - 13 - 18
			50	0.75	36	3,427		4,314		4,638		4,875			12 - 14 - 20
4	B2	4	11	0.25	-	1,967		2,476		2,662		2,798		4.4	1 - 2 - 6
			16	0.50	24	3,014	0.48	3,794	1.93	4,079	4.34	4,288	7.72		2 - 4 - 11
			19	0.75	28	3,367		4,239		4,557		4,790			3 - 6 - 13
	B3	4	21	0.25	17	2,281		2,871		3,087		3,245		3.6	2 - 5 - 12
			30	0.50	29	3,495	0.48	4,400	1.93	4,730	4.34	4,972	7.72		6 - 10 - 16
			37	0.75	33	3,905		4,916		5,285		5,555			8 - 12 - 17
	B4	4	39	0.25	-	2,567		3,231		3,474		3,651		3.0	8 - 12 - 17
			55	0.50	24	3,933	0.48	4,951	1.93	5,323	4.34	5,594	7.72		12 - 15 - 21
			67	0.75	28	4,394		5,531		5,946		6,250			13 - 16 - 23
5	B2	4	14	0.25	-	2,388		3,006		3,232		3,397		4.4	1 - 2 - 7
			20	0.50	26	3,659	0.59	4,606	2.36	4,952	5.31	5,205	1.20		2 - 5 - 12
			25	0.75	30	4,088		5,146		5,533		5,815			3 - 7 - 14
	B3	4	28	0.25	25	3,712		4,673		5,024		5,280		1.20	5 - 9 - 16
			40	0.50	29	4,111	0.59	5,175	2.36	5,564	5.31	5,848	1.20		7 - 11 - 17
			48	0.75	33	4,508		5,675		6,101		6,412			8 - 13 - 19
	B4	6" oval	46	0.25	-	3,116		3,922		4,217		4,432		3.0	8 - 12 - 18
			66	0.50	26	4,775	0.59	6,010	2.36	6,462	5.31	6,792	1.20		14 - 17 - 24
			80	0.75	31	5,334		6,715		7,219		7,588			15 - 19 - 27
6	B2	4	17	0.25	16	2,813		3,541		3,807		4,001		4.4	1 - 2 - 8
			25	0.50	28	4,310	0.70	5,426	2.78	5,833	6.26	6,131	1.44		2 - 5 - 14
			30	0.75	32	4,816		6,062		6,517		6,850			4 - 8 - 16
	B3	4	33	0.25	26	4,842		6,096		6,553		6,888		1.44	5 - 10 - 17
			47	0.50	31	4,530	0.70	5,702	2.78	6,130	6.26	6,443	1.44		8 - 12 - 19
			58	0.75	35	5,310		6,684		7,186		7,553			9 - 14 - 21
	B4	6" oval	60	0.25	23	4,920		6,194		6,659		6,999		1.44	13 - 17 - 24
			85	0.50	29	5,799	0.70	7,300	2.78	7,849	6.26	8,250	1.44		16 - 19 - 27
			104	0.75	34	6,592		8,298		8,921		9,377			17 - 21 - 30



**NOTES:**

1. All performance data based on test performed in accordance with ASHRAE Standard 200-2015
2.  $\Delta P_{Coil}$  values are measured in inches of water
3. NC values are based on room absorption of 10 dB. A dash (-) indicates an NC value less than 15
4. Throw values are based on isothermal supply air and represent throw distances to terminal velocities of 150, 100 and 50 fpm respectively
5.  $\Delta P_{Coil}$  values are measured in feet of water.  $\Delta P_{Coil}$  values in shaded cells indicate use of a two circuit coil. All other values represent a single circuit coil.
6. Induction ratio is multiplied by the volume flow rate of primary air to estimate the volume flow rate of room air entrained through the coil

**Cooling performance:**

- Cooling capacity listed (qCOIL) is the sensible heat removal by the beam’s integral coil. It does not include any contribution or offset by the primary air
- Capacity is based on 18°F  $\Delta T$  between the induced air and the chilled water supply.

**CORRECTION FOR ( $\Delta T$ ) BETWEEN ENTERING AIR AND ENTERING CHILLED WATER TEMPERATURE**

Actual $\Delta T$	10	12	14	16	18	20	22	24
Multiply Table Value by:	0.56	0.67	0.78	0.89	1.00	1.11	1.22	1.33

- Primary air sensible cooling contribution can be calculated by the following equation:

$$qSENSPA = 1.085 \times CFMPA \times (TPA - TROOM)$$

- Primary air latent cooling can be calculated by the following equation:

$$qLATENT = 0.69 \times CFMPA \times (WROOM - WPA)$$

where WROOM and WPA are the humidity ratio of the room and primary air respectively expressed in Grains of moisture per pound dry air

**Heating performance:**

- Heating capacity listed (qCOIL) is the sensible heat removal by the beam’s integral coil. It does not include any contribution or offset by the primary air.
- Capacity is based on 50°F  $\Delta T$  between the induced air and the chilled water supply.
- Primary air sensible heating offset (or contribution) can be calculated by the following equation:

$$qSENSPA = 1.085 \times CFMPA \times (TPA - TROOM)$$

if the primary air temperature is lower than that of the room, it will offset the coil’s heating

if the primary air temperature is higher than that of the room, it will contribute to the coil’s heating

**Legend:**

- |  |  |  |
|--|--|--|
| $\Delta P_s$ = Unit Inlet Pressure [in wg]           | qSENSPA = Sensible Capacity, Primary Air [Btu/h] | TROOM = Temperature Room Air [°F]              |
| qCoil = Sensible Capacity, Coil [Btu/h]              | CFMPA = Air Flowrate, Primary Air [CFM]          | qSENSPA = Latent Capacity, Primary Air [Btu/h] |
| $\Delta P_{Coil}$ = Water coil pressure drop [ft wg] | TPA = Temperature Primary Air [°F]               |  |

# CB-ABW-YK

## DIMENSIONAL INFORMATION

### CB-ABW-YK

MODULE SIZE (FT)	'A' DIMENSION	'C' DIMENSION
2	24"	26 11/64"
3	36"	38 11/64"
4	48"	50 11/64"
5	60"	62 11/64"
6	72"	74 11/64"
7	84"	86 11/64"
8	96"	98 11/64"
9	108"	110 11/64"
10	120"	122 11/64"

NOMINAL INLET	'B' DIMENSION
4" ROUND	3 7/8"
5" ROUND	4 7/8"
6" ROUND	5 7/8"
8" OVAL	9 3/8"

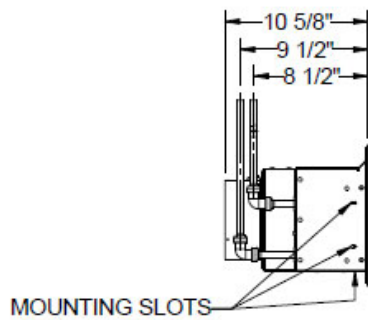
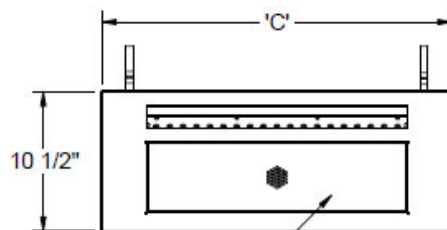
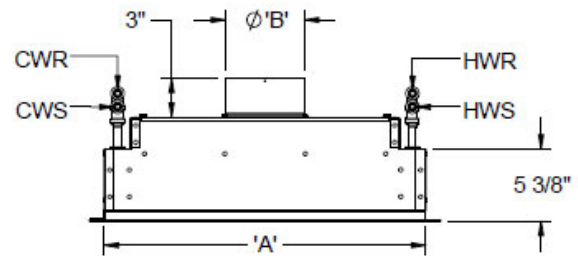
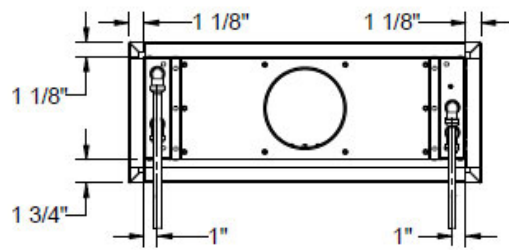

RETURN GRILLE  
(PERFORATED OR LINEAR BAR)

---

Guide Specification:  
CB-ABW-YK Sidewall Active Chilled Beams

PART 1- GENERAL

**1.01 Summary**

This section describes the active chilled beams.

**1.02 Submittals**

Submit product data for all items complete with the following information:

1. Operating weights and dimensions of all unit assemblies.
2. Performance data, including sensible and latent cooling capacities, nozzle types, primary and total supply (primary plus induced) airflow rates, chilled (and where applicable hot) water flow rates, noise levels in octave bands, air and water side pressure losses and maximum discharge air throw values.
3. Construction details including manufacturers recommendations for installation, mounting and connection.

PART 2- PRODUCTS

**2.01 General**

Materials and products required for the work of this section shall not contain asbestos, polychlorinated biphenyls (PCB) or other hazardous materials identified by the engineer or owner.

**2.02 Design**

1. Furnish and install YORK® CB-ABW-YK sidewall active chilled beams of sizes and capacities as indicated on the drawings and within the mechanical equipment schedules. The quantity and length of the beams shall

be as shown on the drawings, without EXCEPTION. The beams shall be constructed and delivered to the job site as single units.

2. The face of the beam shall consist of a room air induction section of 50% free area perforated (optional linear bar type) induction section with integral slot diffuser. The face section shall include hinged fastening on each side that allows the face to be swung out and removed. The entire visible face section shall be finished in white powder coat paint or as specified by the architect. All visible internal surfaces shall be flat black.

3. The beams shall consist of a minimum 20 gauge galvanized steel housing encasing the integral sensible cooling coil and a plenum featuring a series of induction nozzles. A single duct connection shall be provided on either the side or top of the unit. The use of multiple duct connections is NOT ACCEPTABLE.

4. Each beam shall be provided with a pressure tap that may be used to measure the pressure differential between the primary air plenum and the room. Airflow calibration charts that relate this pressure differential reading with the primary and beam supply airflow rates shall be furnished with the beams.

5. Beams shall be provided with connections for either 2 or 4 pipe water connections as indicated on plans and schedules. Four pipe configurations shall require separate supply and return connections for chilled and hot water. The coils shall be mounted vertically and shall be manufactured with seamless copper tubing (1/2" outside diameter) with minimum .016 inch wall thickness mechanically fixed to aluminum fins. The aluminum fins shall be limited to no more than ten (10) fins per inch. The coil shall have a working pressure of at least 300 PSI, and be factory tested for leakage at a minimum pressure of 360 PSI. Each chilled beam shall be provided with factory integrated manual air vents. (OPTIONAL, coil shall be provided with factory integrated drain fittings.)

Unless otherwise specified, coil connections shall be bare copper for field sweating to the water supply circuit. Connections shall face upwards, be located near the left end of the beam (when viewing into the primary air connection). (OPTIONAL, the chilled water coil shall be provided with NPT male threaded fittings. These fittings must be suitable for field connection to a similar NPT female flexible hose spigot and shall be at least 1½" long to facilitate field connection (by others).

6. Beams shall be delivered clean, flushed and capped to prevent ingress of dirt

### **2.03 Performance**

1. All performance shall be in compliance with that shown on the equipment schedule. Acoustical testing shall have been performed in accordance with ASHRAE Standard 200-2015.

2. Coils shall be rated in accordance with AHRI Standard 410, but their cooling and heating capacities shall be established in accordance to ASHRAE Standard 200-2015 for the specific application on the inlet side of the submitted chilled beam.

3. Chilled water flow rates to the beams shall be limited to that which results in a maximum ten (10) foot head loss. Water flow velocities through the beam shall not exceed 4 FPS.

## **PART 3- EXECUTION**

### **3.02 Installation**

1. Coordinate the size, tagging and capacity of the beams to their proper location.

2. Chilled beams shall be fastened to structure/framing utilizing all mounting slots provided.

3. Before connecting the supply water system(s) to

the beams, contractor shall flush the piping system(s) to assure that all debris and other matter have been removed.

4. Contractor shall perform connection of beams to the chilled water circuit by method specified (hard connection using sweated connection or connection using flexible hoses).

5. Flexible connector hoses shall be furnished by others (optionally by the manufacturer). Hoses shall be twenty four (12, 18, or 24) inches in length and suitable for operation with a bend radius as small as five (5) inches. Connector hoses shall consist of a PTFE lined hose with a wire braided jacket. The hoses shall be suitable for operation in an environment between -40 and 200°F, rated for a least 300 PSI and tested for leakage at a minimum pressure of 360 PSI. Contractor shall assure that the chilled water supplying the beams has been properly treated in accordance to BSRIA publication AG 2/93.

6. Utilizing the locating pins provided, position diffuser face, swinging face parallel to sidewall and lower into installed position.

7. No power or direct control connections shall be required for the operation of the chilled beam.

### **3.03 Cleaning and Protection**

1. Air and water connections shall be covered before shipment and remain so until final installation. Damaged material due to improper site protection shall be cause for rejection.

2. Clean equipment, repair damaged finishes as required to restore beams to as-new appearance.



For more information [www.york.com/chilledbeams](http://www.york.com/chilledbeams)

Johnson Controls, the Johnson Controls logo, and YORK® are trademarks of Johnson Controls, Inc., or its affiliates, in the United States of America and/or other countries.

©2016 Johnson Controls, Inc., P.O. Box 423, Milwaukee, WI 53201 Printed in USA PUBL-7949 (Rev. 08/16)

[www.johnsoncontrols.com](http://www.johnsoncontrols.com)

