

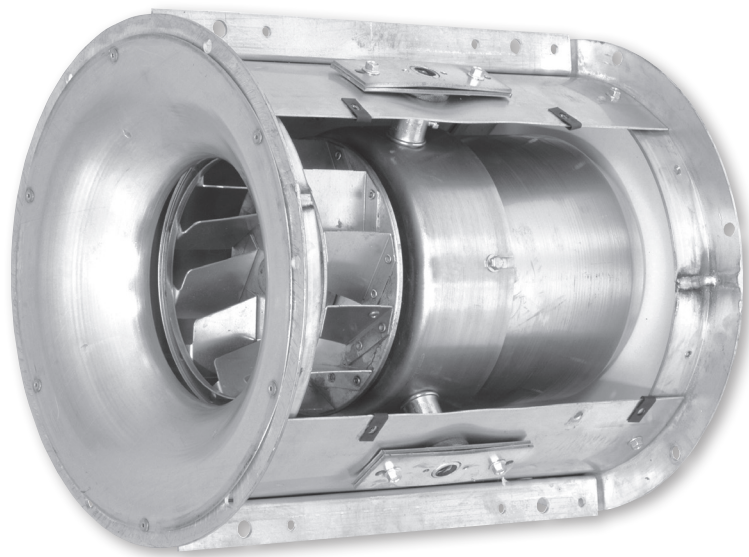

**CIR
Tubular Centrifugal Inline Fan**

OPERATION & MAINTENANCE

Revised: 08/24/15



IMPORTANT! READ BEFORE PROCEEDING!

The information contained herein is, to the best of our knowledge, accurate and applicable for proper operation and installation of the specified equipment at the time this document entered service. Before proceeding, it is recommended that you check for a more current version of this Installation Operation Manual (IOM) on our website at www.johnsoncontrols.com.

Read carefully before attempting to assemble, install, operate or maintain the product described. Protect yourself and others by observing all safety information. Failure to comply with instructions could result in personal injury and/or property damage! Retain instructions for future reference.

INTRODUCTION & INSTALLATION

Centrifugal Inline Fans feature motor compartment cooling to provide a long motor service life. Vanes on the motor housing serve as a heat-sink and assist in dissipating any heat build-up. The entire operation assembly is floated on tubular supports. In belt drive models, motors and drive pulleys are mounted on the exterior so they are readily accessible. An extra-deep spun venturi inlet mates with a spun bottom wheel inlet plate. This smooth inlet condition assures high capacity even at higher static pressures.

Centrifugal Inline Fan's compact circular housing is compatible with round, oval, rectangular or square ducts. All these design features, coupled with low outlet velocities, mean low operating noise levels with smooth, efficient airflow.

RECEIVING AND HANDLING

YORK® by Johnson Controls fans are carefully inspected before leaving the factory. When the unit is received, inspect the carton for any signs of tampering. Inspect the unit for any damage that may have occurred during transit and check for loose, missing or damaged parts. Mishandled units can void the warranty provisions. If units are damaged in transit, it is the responsibility of the receiver to make all claims against the carrier. YORK® by Johnson Controls is not responsible for damages incurred during shipment.

Avoid severe jarring and/or dropping. Handle units with care to prevent damage to components or finishes. If the unit is scratched due to mishandling, the protective coating may be damaged. Incorrect lifting may damage the fan and void the warranty.

STORAGE

Long-term storage requires special attention. Store units on a level, solid surface, preferably indoors. If outside storage is necessary, protect the units against moisture and dirt by encasing the cartons in plastic or in some similar weatherproof material. Periodically inspect units and rotate wheels to spread bearing lubricant. Failure to rotate wheels results in reduced bearing life and may void the manufacturer's warranty. If the unit will be stored for an extended time, remove belts. Belts which remain under tension in a stationary position for extended periods are likely to have a reduced operating life.

UNPACKING

Place the carton in an upright position and remove the staples or use a sharp (knife edge) tool to carefully cut or scribe the sealing tape on both sides at the top of the carton. Open carton flaps. Remove any cardboard and wooden filler pieces, as well as loose components or accessories shipped with the unit.

Carefully remove the unit from the carton. Inspect the unit for any damage that may have occurred during transit and check for loose, missing or damaged parts.

INSTALLATION

Fans must be directly supported by building structure. Follow building's blue prints carefully when installing.

Installing the Dampers

When required, dampers must be positioned and fastened to the duct or fan housing.

Positioning and Running Power Lines

Power is normally brought from within the building through proper conduit lines to the unit. It is then fed to the disconnect switch, if furnished, and motor. For belt driven units, lines can be fastened to the exterior of the unit housing with appropriate fastening devices. For direct drive units, power lines are directed to the motor compartment through one of the motor cooling tubes for connection to the motor terminals in an approved manner.

Anchoring and Securing the Ventilator

CIR fans are designed for all angle mounting. Method of installation is dependent upon job conditions and may, under specific circumstances, require support legs, angle supports or casing brackets. Vibration eliminators, where required, should be installed jointly with the units. Flexible duct connectors are common accessories, and if used, should overlap the duct at least 2".

Inasmuch as these units are cylindrical in shape they will, in many cases, require transition pieces at both ends to connect to the duct. The housing diameter and duct diameter need not be the same size or shape.

It is particularly important to remember that the venturi end is the inlet side of the unit. Position the unit so that the direction of desired airflow will be the same as the arrow on the unit. When the unit has been placed into its proper position, connect it to the duct system. This can be accomplished through companion angle rings which enable the duct to fasten to the inlet and outlet ends of the unit through angle rings provided at those points. When duct transitions are used they can be connected directly to the unit by bolting to mounting holes provided in the angle rings at the inlet and outlet ends of the unit and then to the duct work. Appropriately sized fasteners should be used and drawn secure and tight. Correct fan wheel rotation should be in the direction of the arrow affixed to the unit designating rotation direction. Normally the wheel should rotate clockwise when looking into the inlet side of the unit.

START-UP & OPERATION

START-UP AND OPERATION

Carefully inspect the unit before start-up. All motor bearings should be properly lubricated. All motor fasteners should be securely tightened. Centrifugal wheel should be rotated by hand to insure free movement. (NOTE: Before placing hand on centrifugal wheel or belts, lock out power source.) Check all set-screws and keys. Tighten when necessary.

Check condition of belts and the amount of tension prior to start-up. DO NOT overtighten, as bearing damage will occur. Recommended belt tension should permit deflection of 1/64" of the belt on each side of the belt measured halfway between the pulley centerline. Exercise extreme care when adjusting belts as not to misalign the pulleys. Any misalignment will cause a sharp reduction in belt life and produce squeaky, annoying noises. On units equipped with two or three groove pulleys, adjustments must be made so that there is equal tension on all belts (see Figure 1).

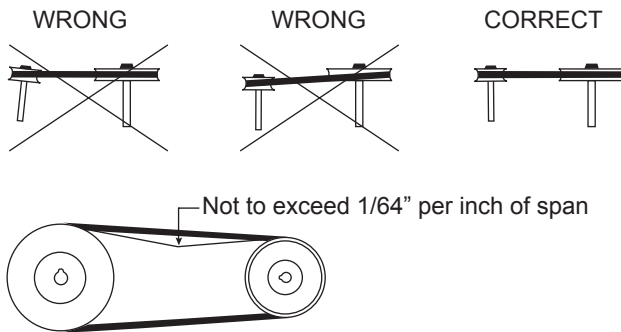

FIGURE 1: PULLEY ALIGNMENT



Whenever belts are removed or installed, never force belts over pulleys without loosening motor first to relieve belt tension.

Make sure inlets and approaches to the unit are free from obstruction. To assure maximum air movement, adequate supply air must be available.

When power lines are brought up to the unit, provide a generous amount of slack to allow for motor deflections and to permit movement of motor for belt tension adjustments. Ground motor adequately and securely. Protect power lines from sharp objects. Do not kink power line or permit it to contact hot surfaces, chemicals, grease or oil. Use only UL recognized electrical parts, rated for proper voltage, load and environment.

Before putting fan into operation, complete the following check list:

1. Lock out primary and secondary power source.
2. Make sure installation is in accordance with manufacturer's instructions.
3. Check and tighten all fasteners.
4. Spin centrifugal wheel to see if rotation is free and doesn't bind or rub.
5. Check all set-screws and keys: tighten if necessary.
6. Torqued set screws have a colored Torque Seal mark indicating the correct torque has been applied.
7. Check belt or direct drive coupling for alignment (use recommended belt tension gauges).
8. Check belt for proper sheave selection.
9. Make sure there is no foreign or loose material in ductwork leading to and from fan or in the fan itself.
10. Properly secure all safety guards.
11. Secure all access doors to fan and ductwork.
12. Check line voltage with motor nameplate.
13. Check wiring.



(On single phase motors, the terminal block must be set up in accordance with the nameplate instructions and/or wiring diagram. This set up must match the line voltage. If the motor is multi-speed or multi-voltage, the winding leads must be grouped and connected as shown on the motor wiring diagram. The line voltage must correspond with proper grouping of motor leads. The wiring diagram must be followed explicitly or serious motor or starter damage will occur.)

The ventilator has been checked at the factory prior to shipment for mechanical noises. If mechanical noises develop:

1. Check rotating components for adequate clearance.
2. Check proper belt tension and pulley alignment.
3. Check installation and anchoring.
4. Check fan bearings. Switch on electrical supply and allow fan to reach full speed.

Check carefully for:

1. Correct rotation of the centrifugal wheel.

START-UP & OPERATION (CONTINUED) AND MAINTENANCE



Incorrect rotation overloads motor severely and results in serious motor damage. To change rotation of three phase units, interchange any 2 of the 3 line leads. On single phase units, change the terminal block set-up following the wiring diagram on the motor.



Use low pressure grease guns only. High pressure guns tend to blow out or unseat bearing seals, leaving the bearing open to collect grime, dust and foreign particles.

2. Check motor and bearing temperatures for excessive heat.



Use care when touching the exterior of an operating motor. Modern motors normally run hot. They are designed to operate at higher temperatures. This is a normal condition but they may be hot enough to be painful or injurious to the touch.

If any problem is indicated, TURN OFF POWER TO UNIT IMMEDIATELY. Lock out the electrical supply, check carefully for the cause of the trouble and correct as needed. Even if the fan appears to be operating satisfactorily, shut down after a brief period and check all fasteners, setscrews and keys for tightness.

During the first eight (8) hours of operation, check the fan periodically for excessive vibration or noise. At this time, also check motor input current and motor bearing temperatures to insure that they do not exceed manufacturer's recommendations. After eight hours of satisfactory operation, shut down the fan and lock out the electrical power to check the following items and adjust if necessary:

1. All set-screws, keys and fasteners.
2. Drive coupling alignment.
3. Belt alignment.
4. Belt tension.

MAINTENANCE

Do not attempt maintenance on fan until the electrical supply has been completely disconnected. If a disconnect switch has not been provided, remove all fuses from the circuit and lock the fuse panel so they cannot be accidentally replaced. Lubrication is a primary maintenance responsibility. Check all bearings periodically. Inspect belts for tightness. If the fan is installed in a corrosive or dirty atmosphere, periodically clean the centrifugal wheel, inlet, motor housing and other moving parts.

Fan Shaft Lubrication

Fan shaft bearing pillow blocks are furnished in either the prelubricated sealed for life type or the greasable type depending on what was ordered. The prelubricated type requires no servicing for 7 to 10 years of normal use and the greasable type are factory greased eliminating the need for greasing initially. Follow the lubricating schedule recommended by the factory. This practice should not supersede any safety considerations.

Lubrication Schedule

Always follow the bearing manufacturer's recommended lubrication schedule. If none is available use the following general schedule.

1. Under average conditions where ambient temperatures do not exceed 120°F., lubrication is required 1 to 2 times a year.
2. Under dirt laden atmosphere where there is a temperature range of 120°F to 150°F, lubrication is required from 3 to 6 times a year.
3. Under extreme temperature conditions and extremely dirty atmospheres, lubrication should be scheduled at least once or twice a month.
4. Belt drive units maximum temperature should not exceed 160°F. Direct driven models have temperature range stamped on motor.

Motor Lubrication

In general, standard motors are furnished with prelubricated, sealed-for-life ball bearings which require no lubrication for 7 to 10 years of normal service. Where motors have been ordered with greasable bearings, these bearings are factory lubricated and require no attention for one year under normal conditions. If grease relief fittings are provided, remove them when performing maintenance to allow grease to flow out. Whenever possible, apply grease while the motor is running. This practice should not supersede any safety considerations. DO NOT OVERGREASE, as most lubricants deteriorate motor windings, thereby reducing motor life.

RECOMMENDED LUBRICANTS

Manufacturer	Product	Temperature Range
BP	LG-#P-1	Below 32°F (0°C)
Gulf	Gulfcrown EP-1	
Imperial Oil	Unirex EP-1	
Shell	Alvania R-1	
BP	Energrease, MPMK11	32°F to 150°F (0°C to 66°C)
Gulf	Gulfcrown EP-2	
Imperial Oil	Unirex EP-2	
Shell	Alvania R-3	
Sun Oil	Sun Prestige 42	
Texaco	Regal AFB2	

SPECIAL PURPOSE SYSTEMS, HIDDEN DANGER & GUARDS

SPECIAL PURPOSE SYSTEMS

Explosive, corrosive, high temperatures, etc. may require special construction, inspection and maintenance. It is necessary to observe the fan manufacturer's recommendations and limitations concerning the type of material to be handled by the fan and its application to special conditions.

HIDDEN DANGER

In addition to the normal dangers of rotating machinery, fans present an additional hazard in their ability to suck in not only air, but loose material as well. Solid objects can pass through the fan and be discharged by the impeller as potentially dangerous projectiles. Therefore, screen intake to ductwork, whenever possible, to prevent the accidental entrance of solid objects. Never open access doors to a duct system with the fan running.

On the downstream (or pressure) side of the system, releasing the door with the system in operation may result in an explosive opening. On the upstream (or suction) side, the inflow may be sufficient to suck tools and clothing, etc., and may even cause a man to lose his balance.

When a fan is being started for the first time, a complete inspection of the duct work and interior of the fan should be made (with the power locked off), to make certain there is no foreign material which can be sucked into or blown through the duct work.

GUARDS

All fans have moving parts which require guarding in the same way as other moving machinery. In areas which are accessible only to experienced personnel, a standard industrial type guard may be adequate. This type of guard will prevent the entry of thrown or dropped objects with a minimum restriction of air flow.

Where the fan is accessible to untrained personnel or the general public, use maximum safety guards, even at the cost of some performance loss. Unprotected fans located less than 7' above the floor also require guarding as specified in the Occupational Safety and Health Act (OSHA). Roof mounted equipment will require guards when access is possible.

Centrifugal fans may be connected directly to ductwork which will prevent contact with the internal moving parts, but when the inlet or outlet is exposed, install a suitable guard. YORK® by Johnson Controls recommends the use of guards on all exposed non-ducted fans, ceiling and wall mounted.

PARTS REPLACEMENT

TYPICAL PARTS

If replacing parts, do so with properly selected components which duplicate the original parts correctly. Incorrectly sized shafts, belts, pulleys, centrifugal wheels, etc. can damage the fan.

Item	Description
1	Spun Venturi Inlet
2	Mounting Angle Ring
3	Outer Fan Casing
4	Motor Support Housing
5	Motor Bearing* Compartment
6	Removable Motor or Bearing* Compartment Cover
7	Motor Cooling Tubes, Supports and Electrical Conduit Guide
8	Centrifugal Fan Wheel
9	Vibration Isolators
10	Straightening Vane
11	Gasketed Access Panel
12	Suspension Angle Supports
13	Ball Bearing Motor
14	Belt Guide Enclosure*
15	Wheel Shaft and Bearings*
16	Belt and Pulleys*
17	Bearing Support Frame*
18	Adjustable Motor Frame*

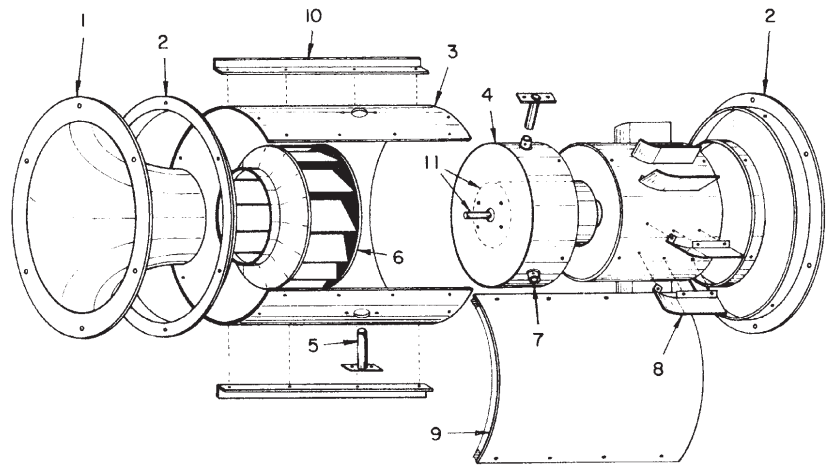

DIRECT DRIVE

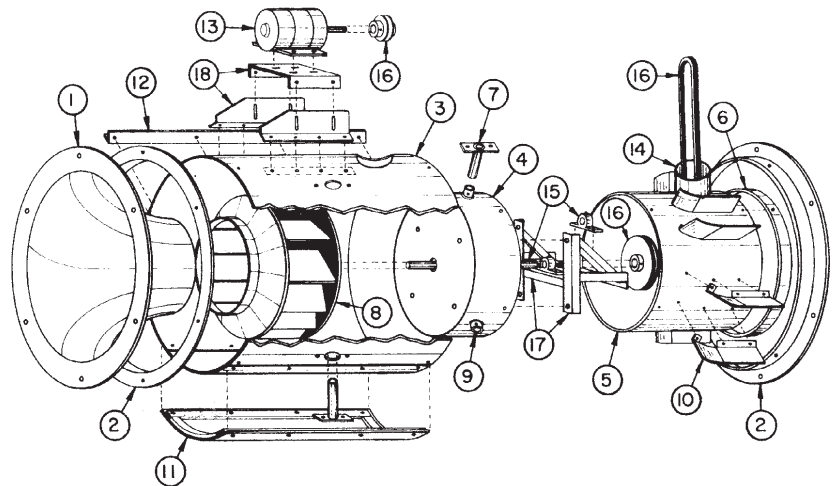

BELT DRIVE

TROUBLESHOOTING CHECKLIST

Symptom	Possible Cause(s)	Corrective Action
Excessive Noise	<ol style="list-style-type: none"> 1. Defective or loose motor bearings. 2. Ventilator base not securely anchored. 3. Loose or unbalanced wheel/propeller. 4. Misaligned pulleys or shaft. 5. Loose or damaged wheel/propeller. 6. Wheel running in wrong direction. 	<ol style="list-style-type: none"> 1. Replace motor with same frame size, RPM, HP. 2. Reset properly. 3. Tighten screws, remove build-up, balance wheel/propeller. 4. Correct alignment. 5. Replace wheel/propeller. 6. Reverse direction.
Fan Inoperative	<ol style="list-style-type: none"> 1. Blown fuse or open circuit breaker. 2. Loose or disconnected wiring. 3. Defective motor. 4. Broken belts. 	<ol style="list-style-type: none"> 1. Replace fuses or circuit breaker. 2. Shut off power and check wiring for proper connections. 3. Repair or replace motor. 4. Replace belts.
Insufficient Airflow	<ol style="list-style-type: none"> 1. Open access doors or loose sections of ducts. 2. Clogged filters. 3. Operation in wrong direction. 4. Insufficient make-up air direction. 	<ol style="list-style-type: none"> 1. Check for leakage. 2. Clean filters. 3. Correct rotation of wheel. 4. Add make-up fan or louver opening.
Water Leaking into Ductwork or Collection of Grease Under Fan	<ol style="list-style-type: none"> 1. Fan installed with slope in the wrong direction. 2. Clogged drain spout. 3. Cooling tube or motor dome top removed. 4. Grease container full. 	<ol style="list-style-type: none"> 1. Slope should be fitted in the direction of the drainage opening or grease collection box and drain spout. 2. Clean drain spout. 3. Install new cooling tube with gasket and dome top. 4. Empty grease box.
Motor Overheating	<ol style="list-style-type: none"> 1. Belt slippage. 2. Overvoltage or under voltage. 3. Operation in wrong direction. 4. Fan speed too high. 5. Incorrect motor. (service factor 1.0, low ambient temp.) 6. Blocked cooling tube or leaky gasket. 7. Insufficient airflow to kitchen hood fan operating on low speed with kitchen in full operation. 8. Undersized motor. 	<ol style="list-style-type: none"> 1. Adjust tension or replace belts. 2. Contact power supply company. 3. Reverse direction of motor. 4. Slow down fan by opening variable pitch pulley on motor shaft. 5. Replace motor with correct open, NEMA service factors (1.15 or higher) with 40 degrees ambient. 6. Remove blockage and seal cooling tube in place. 7. Check airflow under hood and adjust kitchen equipment output. 8. Check motor ratings with catalog speed and air capacity chart.

Note: Care should be taken to follow all local electrical, safety and building codes. Provisions of the National Electric Code (NEC), as well as the Occupational Safety and Health Act (OSHA) should be followed.

All motors are checked prior to shipment. If motor defects should develop, prompt service can be obtained from the nearest authorized service station of the motor manufacturer while under warranty. Exchange, repair or replacement will be provided on a no charge basis if the motor is defective within the warranty period. The YORK® by Johnson Controls representative in your area will provide a name and address of an authorized service station if requested.

WARNING: Motor guarantee is void unless overload protection is provided in motor wiring circuit.



P.O. Box 1592, York, Pennsylvania USA 17405-1592
Copyright © by Johnson Controls 2015
Revised: 08/24/15

Tele. 800-861-1001
www.york.com

Subject to change without notice. Printed in USA
ALL RIGHTS RESERVED

For Product Warranty Support and Parts call 814-479-4005