



**MAF**  
**Fresh Air Make-Up, Filtered Supply Fans**

OPERATION & MAINTENANCE

Revised: 08/24/15



---

# **IMPORTANT!**

## **READ BEFORE PROCEEDING!**

The information contained herein is, to the best of our knowledge, accurate and applicable for proper operation and installation of the specified equipment at the time this document entered service. Before proceeding, it is recommended that you check for a more current version of this Installation Operation Manual (IOM) on our website at [www.johnsoncontrols.com](http://www.johnsoncontrols.com).

Read carefully before attempting to assemble, install, operate or maintain the product described. Protect yourself and others by observing all safety information. Failure to comply with instructions could result in personal injury and/or property damage! Retain instructions for future reference.

# INTRODUCTION & INSTALLATION

---

## RECEIVING AND HANDLING

YORK® by Johnson Controls fans are carefully inspected before leaving the factory. When the unit is received, inspect the carton/crate for any signs of tampering. Inspect the unit for any damage that may have occurred during transit and check for loose, missing or damaged parts. Mishandled units can void the warranty provisions. If units are damaged in transit, it is the responsibility of the receiver to make all claims against the carrier. YORK® by Johnson Controls is not responsible for damages incurred during shipment.

Avoid severe jarring and/or dropping. Handle units with care to prevent damage to components or finishes. If the unit is scratched due to mishandling, the protective coating (if supplied) may be damaged. Incorrect lifting may damage the fan and void the warranty.

## STORAGE

Long-term storage requires special attention. Store units on a level, solid surface, preferably indoors. If outside storage is necessary, protect the units against moisture and dirt by encasing the carton/crates in plastic or in some similar weatherproof material. Periodically inspect units and rotate wheels to spread bearing lubricant. Failure to rotate wheels results in reduced bearing life and may void the manufacturer's warranty. If the unit will be stored for an extended time, remove belts. Belts which remain under tension in a stationary position for extended periods are likely to have a reduced operating life.

## UNPACKING

Place the carton/crate in an upright position and remove the staples or use a sharp (knife edge) tool to carefully cut or scribe the sealing tape on both sides at the top of the carton/crate. Open carton/crate flaps. Remove any cardboard and wooden filler pieces, as well as loose components or accessories shipped with the unit.

Carefully remove the unit from the carton/ crate. Inspect the unit for any damage that may have occurred during transit and check for loose, missing or damaged parts.

## INSTALLATION

### Roof Mounting

Before installation, make sure the unit is not located next to an exhaust fan so dirty or noxious air is not brought back inside the building. Mounting the unit on a roof necessitates prior installation of the proper height and size roof curb. Curb must be installed securely and sealed carefully to the roof construction. Dampers, when required, should be installed prior to mounting on the curb. Dampers must be secured to the inside of the curb without undue twisting which may distort the damper frame. Damper frame must be reasonably level on all sides. Check for free operation. If dampers are motor operated type, ascertain that proper voltage is impressed on motor terminals.

### Positioning and Running Power Lines

Power is normally brought from within the building through proper conduit lines and placed inside one corner of the curb. It is then fed through the clearance hole provided in the damper and, in turn, fed through the fan to the disconnect switch, if furnished. Number of wires, type of insulation and protection by metal rigid or flexible conduit must be suitable for motor load on line voltage service.

*NOTE: Care should be taken to follow all local electrical safety and building codes. All electrical parts must be grounded and grounding conductor should be checked for continuity.*

Some local codes prohibit the connection of in-line, aluminum fans in kitchen hood exhaust systems. According to present NFPA96 interpretation, ANY fan used in such duct work must be made of steel, with liquid-tight welds at all seams and connections. If local codes are in accordance with NFPA96 do not use ANY fan that is not NFPA96 do not use ANY fan that is not completely welded closed for such duty.

### Anchoring and Securing the Fan

Units should be seated on properly sized curb. Gap between base of the fan and top of the curb should be sealed with neoprene 1" X 1/4" gasket. Gasket should be glued or attached with pressure-sensitive adhesive. The fan must be firmly secured to metal curb with stainless steel or cadmium coated self-tapping screws, 18" on center. Units installed in areas subject to high winds or unusual field conditions, may require additional fastening with guy wires. If the contractor removes the ventilator parts to facilitate installation and electrical connections, all parts should be reassembled replacing all spacers, washers, nuts, bolts, fasteners and components exactly as they were found prior to removal. All fasteners are to be drawn tight and secure.

# START-UP AND OPERATION

## START-UP AND OPERATION

Careful inspection should be made before starting up. Make sure that all instructions on labels are understood and executed. All motor bolts should be securely tightened. Blower wheels should be rotated by hand to insure free movement. Lock out power supply before rotating wheel. The inlet louvers should be clean and free from obstruction.

Check condition of belts and the amount of tension prior to start-up. DO NOT overtighten, as bearing damage will occur. Recommended belt tension should permit deflection of 1/64" of the belt on each side of the belt measured halfway between the pulley centerline. Exercise extreme care when adjusting belts as not to misalign the pulleys. Any misalignment will cause a sharp reduction in belt life and produce noise. On units equipped with two or three groove pulleys, adjustments must be made so that there is equal tension on all belts (see FIG 1).

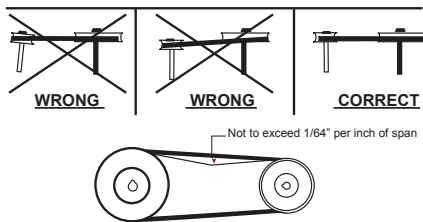

FIGURE 1: PULLEY ALIGNMENT & TENSION



*Whenever belts are removed or installed, never force belts over pulleys without loosening motor first to relieve belt tension.*

Before putting fan into operation, complete the following check list:

1. Lock out primary and secondary power source.
2. Make sure installation is in accordance with manufacturer's instructions.
3. Check and tighten all fasteners.
4. Spin centrifugal wheel to see if rotation is free and doesn't bind or rub.
5. Check all set-screws and keys: tighten if necessary.
6. Check belt for alignment (use recommended belt tension gauges).
7. Check belt for proper sheave selection (make sure not in reverse position).
8. Make sure there is no foreign loose material in ductwork leading to and from fan or in the fan itself.
9. Properly secure all safety guards.
10. Secure all access doors to fan and ductwork.
11. Check line voltage with motor nameplate.
12. Check wiring.



*(On single phase motors, the terminal block must be set up in accordance with the nameplate instructions and/or wiring diagram. This set up must match the line voltage. If the motor is multi-speed or multi-voltage, the winding leads must be grouped and connected as shown on the motor wiring diagram. The line voltage must correspond with proper grouping of motor leads. The wiring diagram must be followed explicitly or serious motor or starter damage will occur.)*

# MAINTENANCE AND FILTERS

## MAINTENANCE

Do not attempt maintenance on fan until the electrical supply has been completely disconnected. If a disconnect switch has not been provided, remove all fuses from the circuit and lock the fuse panel so they cannot be accidentally replaced. Lubrication is a primary maintenance responsibility. Check all bearings periodically. Inspect belts for tightness. If the fan is installed in a corrosive or dirty atmosphere, periodically clean the centrifugal wheel, inlet, motor housing and other moving parts.

### Fan Shaft Lubrication

Fan shaft bearing pillow blocks are furnished in the greasable type are factory greased eliminating the need for greasing initially. Follow the lubricating schedule recommended by the factory. This practice should not supersede any safety considerations.



*Use low pressure grease guns only. High pressure guns tend to blow out or unseat bearing seals, leaving the bearing open to collect grime, dust and foreign particles.*

### Lubrication Schedule

Always follow the bearing manufacturer's recommended lubrication schedule. If none is available use the following general schedule.

1. Under average conditions where ambient temperatures do not exceed 120°F., lubrication is required 1 to 2 times a year.
2. Under dirt laden atmosphere where there is a temperature range of 120°F to 150°F, lubrication is required from 3 to 6 times a year.
3. Under extreme temperature conditions and extremely dirty atmospheres, lubrication should be scheduled at least once or twice a month.
4. Belt drive units maximum temperature should not exceed 160°F. Direct driven models have temperature range stamped on motor.

## Motor Lubrication

In general, standard motors are furnished with pre-lubricated, sealed-for-life ball bearings which require no lubrication for 7 to 10 years of normal service. Where motors have greasable bearings, these bearings are factory lubricated and require no attention for one year under normal conditions. If grease relief fittings are provided, remove them when performing maintenance to allow grease to flow out. Whenever possible, apply grease while the motor is running. This practice should not supersede any safety considerations. **DO NOT OVER-GREASE**, as most lubricants deteriorate motor windings, thereby reducing motor life.

**TABLE 1: RECOMMENDED LUBRICANTS**

Manufacturer	Product	Temperature Range
BP	LG-#P-1	Below 32°F (0°C)
Gulf	Gulfcrown EP-1	
Imperial Oil	Unirex EP-1	
Shell	Alvania R-1	
BP	Energrease MPMK11	32°F to 150°F (0°C to 66° C)
Gulf	Gulfcrown EP-2	
Imperial Oil	Unirex EP-2	
Shell	Alvania R-3	
Sun Oil	Sun Prestige 42	
Texaco	Regal AFB2	

## FILTERS

Filters are an integral part of the unit. The filters are washable aluminum mesh with sizes and quantities per model listed below. Filter inspection and cleaning intervals will vary depending upon the amount of contaminant present and when this will raise the pressure drop across the filters to an unacceptable level. To clean the filters, first remove the screws in the cap and remove the cap. The filters can then be pulled straight up and out of the filter tracks through the top of the unit. Use a brush or vacuum for dry dust and contaminants. Then rinse with water in the opposite direction of airflow through the filter. For contaminants that are not easily removed with water a light detergent can be used. Filters should be allowed to dry thoroughly and then placed back within the filter tracks. Replace the cap and all screws as originally found.

# SPECIAL PURPOSE SYSTEMS, HIDDEN DANGER, AND GUARDS

---

## SPECIAL PURPOSE SYSTEMS

Explosive, corrosive, high temperatures, etc. may require special construction, inspection and maintenance. It is necessary to observe the fan manufacturer's recommendations and limitations concerning the type of material to be handled by the fan and its application to special conditions.

## HIDDEN DANGER

In addition to the normal dangers of rotating machinery, fans present an additional hazard in their ability to suck in not only air, but loose material as well. Solid objects can pass through the fan and be discharged by the impeller as potentially dangerous projectiles. Therefore, screen intake to ductwork, whenever possible, to prevent the accidental entrance of solid objects. Never open access doors to a duct system with the fan running.

On the downstream (or pressure) side of the system, releasing the door with the system in operation may result in an explosive opening. On the upstream (or suction) side, the inflow may be sufficient to suck tools and clothing, etc., and may even cause a man to lose his balance.

When a fan is being started for the first time, a complete inspection of the duct work and interior of the fan should be made (with the power locked off), to make certain there is no foreign material which can be sucked into or blown through the duct work.

## GUARDS

All fans have moving parts which require guarding in the same way as other moving machinery. In areas which are accessible only to experienced personnel, a standard industrial type guard may be adequate. This type of guard will prevent the entry of thrown or dropped objects with a minimum restriction of air flow.

Where the fan is accessible to untrained personnel or the general public, use maximum safety guards, even at the cost of some performance loss. Unprotected fans located less than 7' above the floor also require guarding as specified in the Occupational Safety and Health Act (OSHA). Roof mounted equipment will require guards when access is possible.

Centrifugal fans may be connected directly to ductwork which will prevent contact with the internal moving parts, but when the inlet or outlet is exposed, install a suitable guard. YORK® by Johnson Controls recommends the use of guards on all exposed non-ducted fans, ceiling and wall mounted.

# PARTS REPLACEMENT

## PARTS REPLACEMENT

When replacing parts, do so with properly selected components which duplicate the original parts correctly. Incorrectly sized shafts, belts, pulleys, centrifugal wheels, etc. can damage the fan.

- **DON'T:** Decrease size of driven pulleys - overspreading will overload motors and blow wheels.
- **DON'T:** Increase size of driver pulleys.
- **DON'T:** Change section "A" belts to "B" or single groove design to two groove type.
- Heavier belts require extra tension which will decrease life of bearings.
- **DON'T:** Change type of filters specially of unknown efficiency and loading capacity.

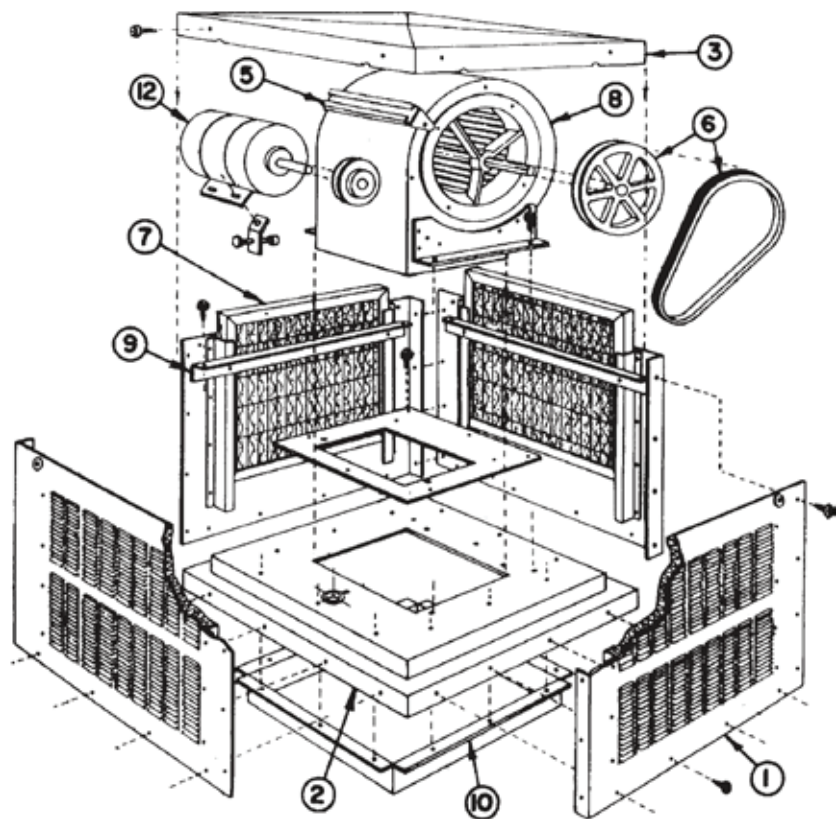

FIGURE 2: BELT DRIVE

Item	Description	Item	Description
1	Stamped Louver Panel	7	Cleanable Filters
2	Base	8	Blower Housing
3	Roof Cap	9	Spreader Bar
4	Blank Side Panel	10	Angle Support Frame
5	Motor Mounting Panel	11	Center Support Channel
6	Belt and Pulleys	12	Thermally Protected Motor



# TROUBLESHOOTING CHECKLIST

Symptom	Possible Cause(s)	Corrective Action
Excessive Noise	<ol style="list-style-type: none"> <li>1. Defective or loose motor bearings.</li> <li>2. Ventilator base not securely anchored.</li> <li>3. Loose or unbalanced wheel/propeller.</li> <li>4. Misaligned pulleys or shaft.</li> <li>5. Loose or damaged wheel/propeller.</li> <li>6. Wheel running in wrong direction.</li> </ol>	<ol style="list-style-type: none"> <li>1. Replace motor with same frame size, RPM, HP.</li> <li>2. Reset properly.</li> <li>3. Tighten screws, remove build-up, balance wheel/propeller.</li> <li>4. Correct alignment.</li> <li>5. Replace wheel/propeller.</li> <li>6. Reverse direction.</li> </ol>
Fan Inoperative	<ol style="list-style-type: none"> <li>1. Blown fuse or open circuit breaker.</li> <li>2. Loose or disconnected wiring.</li> <li>3. Defective motor.</li> <li>4. Broken belts.</li> </ol>	<ol style="list-style-type: none"> <li>1. Replace fuses or circuit breaker.</li> <li>2. Shut off power and check wiring for proper connections.</li> <li>3. Repair or replace motor.</li> <li>4. Replace belts.</li> </ol>
Insufficient Airflow	<ol style="list-style-type: none"> <li>1. Open access doors or loose sections of ducts.</li> <li>2. Clogged filters.</li> <li>3. Operation in wrong direction.</li> <li>4. Insufficient make-up air direction.</li> </ol>	<ol style="list-style-type: none"> <li>1. Check for leakage.</li> <li>2. Clean filters.</li> <li>3. Correct rotation of wheel/propeller.</li> <li>4. Add make-up fan or louver opening.</li> </ol>
Water Leaking into Ductwork or Collection of Grease Under Fan	<ol style="list-style-type: none"> <li>1. Fan installed with slope in the wrong direction.</li> <li>2. Clogged drain spout.</li> <li>3. Cooling tube or motor dome top removed.</li> <li>4. Grease container full.</li> </ol>	<ol style="list-style-type: none"> <li>1. Slope should be fitted in the direction of the drainage opening or grease collection box and drain spout.</li> <li>2. Clean drain spout.</li> <li>3. Install new cooling tube with gasket and dome top.</li> <li>4. Empty grease box.</li> </ol>
Motor Overheating	<ol style="list-style-type: none"> <li>1. Belt slippage.</li> <li>2. Overvoltage or under voltage.</li> <li>3. Operation in wrong direction.</li> <li>4. Fan speed too high.</li> <li>5. Incorrect motor (service factor 1.0, low ambient temperature).</li> <li>6. Blocked cooling tube or leaky gasket.</li> <li>7. Insufficient airflow to kitchen hood fan operating on low speed with kitchen in full operation.</li> <li>8. Undersized motor.</li> </ol>	<ol style="list-style-type: none"> <li>1. Adjust tension or replace bad belts.</li> <li>2. Contact power supply company.</li> <li>3. Reverse direction of motor.</li> <li>4. Slow down fan by opening variable pitch pulley on motor shaft.</li> <li>5. Replace motor with correct open, NEMA service factors (1.15 or higher) with 40 degrees ambient.</li> <li>6. Remove blockage and seal cooling tube in place.</li> <li>7. Check airflow under hood and adjust kitchen equipment output.</li> <li>8. Check motor ratings with catalog speed and air capacity chart.</li> </ol>

*Note: Care should be taken to follow all local electrical, safety and building codes. Provisions of the National Electric Code (NEC), as well as the Occupational Safety and Health Act (OSHA) should be followed.*

All motors are checked prior to shipment. If motor defects should develop, prompt service can be obtained from the nearest authorized service station of the motor manufacturer while under warranty. Exchange, repair or replacement will be provided on a no charge basis if the motor is defective within the warranty period. The YORK® by Johnson Controls representative in your area will provide a name and address of an authorized service station if requested.

**WARNING: Motor guarantee is void unless overload protection is provided in motor wiring circuit.**



P.O. Box 1592, York, Pennsylvania USA 17405-1592  
Copyright © by Johnson Controls 2015  
Revised: 08/24/15

Tele. 800-861-1001  
[www.york.com](http://www.york.com)

Subject to change without notice. Printed in USA  
ALL RIGHTS RESERVED

For Product Warranty Support and Parts call 814-479-4005